



INSTALLATION, OPERATION AND MAINTENANCE MANUAL

CC MODEL CHANNEL GATE



INDEXPage

0. Introduction	2
1. Handling and Storage.....	2
2. Installation	3
2.1. Installation: Embedded in Concrete.....	3
2.2. Installation: Face Mounted in Existing Channel.....	5
2.3. Installation: Wall Mounted.....	7
3. Operation.....	9
4. Maintenance.....	10
4.1. Cleaning and lubrication.....	10
4.2. Side Seals and Bottom Seal replacement.....	11
5. Trouble shooting.....	12
6. Annex: civil work acceptable tolerance.....	13
7. Environmental considerations.....	14

0. INTRODUCTION

- This manual describes the recommended procedures for installation, operation, maintenance and safety precautions for ORBINOX CC model channel gates
- Please read thoroughly all the instructions in the manual prior to installation, and contact an ORBINOX representative in case of any questions
- The manual makes reference to the “General Arrangement Drawing” (GAD). The GAD is the drawing that is sent to and approved by the customer prior to the production of the gate
- **ORBINOX assumes no responsibility or liability if the CC channel gate is not installed, operated and maintained in strict accordance to the procedures described in this manual**

1. HANDLING AND STORAGE

Standard safety procedures should be followed to prevent personal injury or equipment damage. Additionally, the following instructions shall be followed during handling and storage to prevent any damage to the product:

- Stems have precision surfaces and should never be used as a means to lift the slide gate
- Equipment shall be stored in a dry, clean and even area on a raised even wood surface to prevent distortion of the frame.
- Do not stack slide gates
- Stems and extensions that are shipped separately shall be supported over their entire length to prevent any bending or distortion while in storage

2. INSTALLATION

In order to avoid personal injury or damage to property when handling and installing the Channel Gate, it is important to observe the following warnings:

- Qualified and trained personnel must carry out the handling and maintenance of the Channel Gate
- Use suitable Individual Protection Equipment (IPE) (gloves, safety footwear...)

2.1. Installation: embedded in concrete

► Required Materials:

As a standard, ORBINOX CC Channel Gates are mounted Embedded in Concrete (EC). Field adjustment hex bolts are required to center the gate in the appropriate recess prior to embedding in concrete. For detailed information about the type, size and quantity of the required bolts, or any other specific installation notes or materials, please refer to the notes on the "General Arrangement Drawing".

► Installation procedure:

Step 1: Concrete construction inspection

- The concrete construction shall be flat, level and plumb, and shall be in accordance to DIN 18202 or ACI 117-06 standards (see section 6). If necessary, use non-shrink grout in order to meet the specified standard. The minimum concrete strength shall be 25Mpa (3,625 PSI)

Step 2: Align the channel gate in the wall recess

- Position and center the channel gate in the recess of the wall, using the field adjustment bolts screwed in the "Side Centering Fittings" and "Bottom Leveling Brackets" (see Figure 1). Make sure that the channel gate is centered in the channel.

NOTE: the smaller CC Channel Gates do not come with "Bottom Leveling Brackets". If this is the case, follow Step 1B prior to starting with "Step 2" in order to be able to align the gate vertically

- Align the gate vertically adjusting the bolts on the "Bottom Leveling Brackets" (see Figure 2). Make sure that the frame invert is flush with the invert of the channel
- Align the gate horizontally adjusting the bolts on the "Lateral Centering Fittings" (see Figure 3). Make sure that the Frame Guide is flush with the channel side wall. Additionally, make sure that the gate is perpendicular to the side walls of the channel

Step 3: Embed the channel gate in the wall recess

- Pour the second phase of concrete. Take special care not to damage the seals
- Do not pour in more than one meter concrete columns to avoid damage to the frame

Note: do not embed in concrete the metal faces that are in contact with the seals

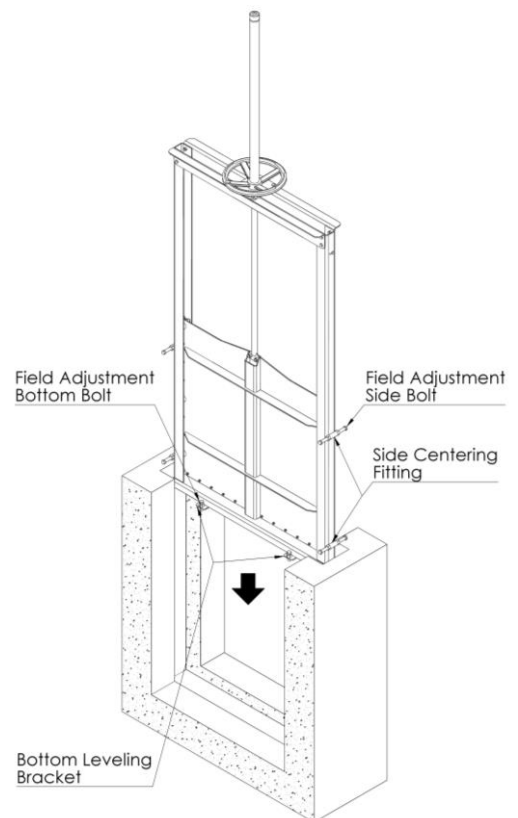

Figure 1

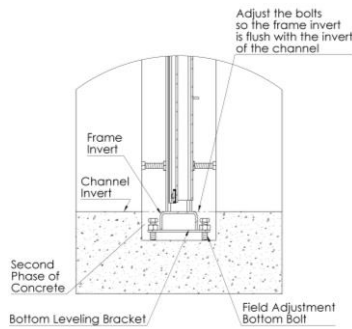

Figure 2

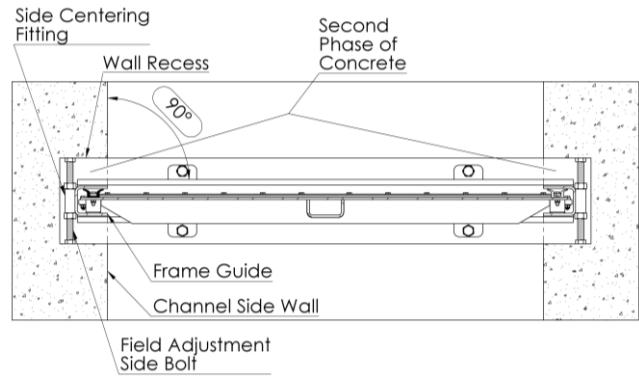

Figure 3

Step 1B: Align the gate vertically (without the Bottom Balancing Brackets)

Smaller CC Channel Gates do not come with “Bottom Balancing Brackets”. Therefore, the following procedure shall be followed to align the gate vertically (After “Step 1”):

- Get two parts as support in order to levelling the channel gate vertically (“Supports”). Rise the slide enough to introduce the two supports between the frame and slide and close the slide to fix the supports (See Figure 4)
- Proceed with “Step 2”. When the gate is positioned in the recess, the supports will maintain the frame invert flush with the invert of the channel (See Figure 4)

CAUTION!: Do not use pieces of wood or metal with sharp edges or with a bad surface condition in order to avoid any damage to the bottom seal.

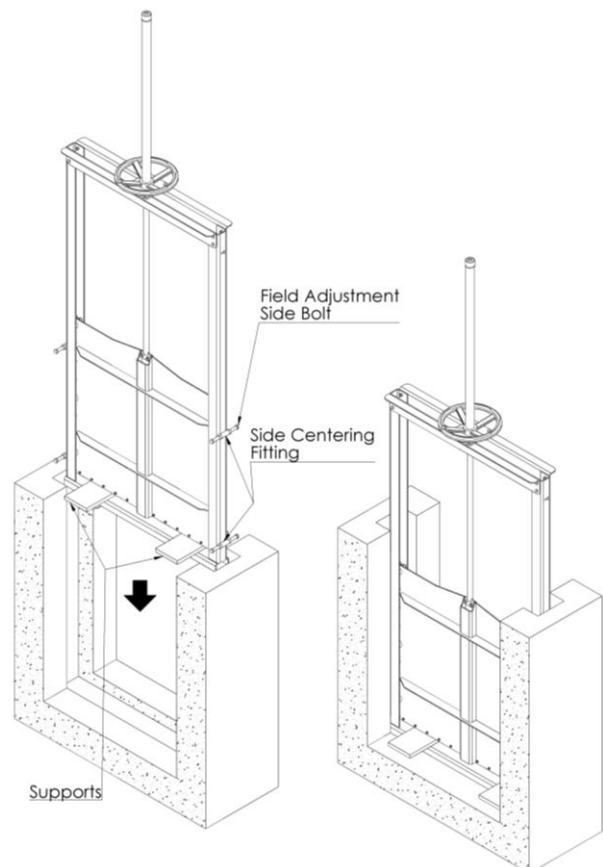

Figure 4

2.2. Installation: face mounted in existing channel

Required Materials:

- For the Face Mounted in Existing Channel (FM) mounting option, the CC channel gate is installed by means of mechanical anchor bolts. All the gaps shall be grout filled afterwards and shaped in order to get a smooth transition. For detailed information about the type, size and quantity of the required anchor bolts or any other specific installation notes or materials, please refer to the notes on the "General Arrangement Drawing".

Installation Procedure:

Step 1: Concrete construction inspection

- The concrete construction shall be flat, level and plumb, and shall be in accordance to DIN 18202 or ACI 117-06 standards. If necessary, use non-shrink grout in order to meet the specified standard. The minimum concrete strength shall be 25Mpa (3,625 PSI)

Step 2: Anchor the gate to the channel

- Position the channel gate in the existing channel. Make sure that the gate is perfectly aligned and centered in the channel (see Figure 6).
- Install the bottom anchor bolts, and then the lateral anchor bolts (see Figure 7). All Face Mounted Channel Gates incorporate bottom and lateral mounting brackets. For smaller sizes (typically same or under 1500mm/60"), the channel gate includes lateral flexible brackets (as seen in Figure 8) that require no field adjustment. For bigger sizes (typically over 1500mm/60"), the channel gate includes "Field Adjustment Brackets". In order to adjust the bracket, the following steps shall be followed (see Figure 5):
 - Untighten nut
 - Adjust the bracket until it is completely leaning against the wall.
 - Tight the nut
 - Install the anchor bolt

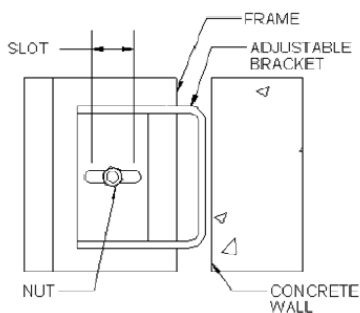

Figure 5

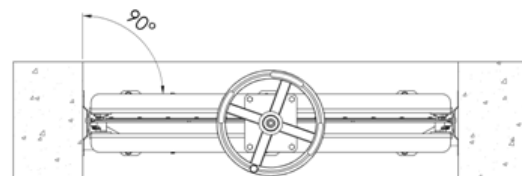

Figure 6

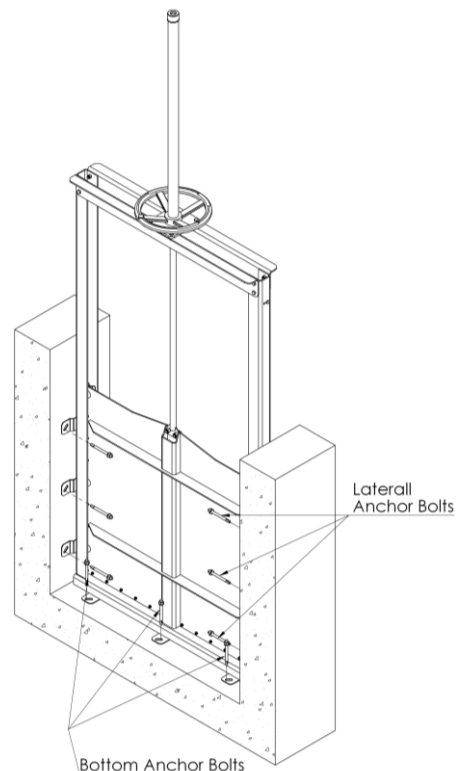

Figure 7

Step 3: Grout fill

- Grout fill the remaining voids (See Figure 8), both at the bottom and laterals of the gate. Remember that the objective of the grout fill is twofold:
 - Fill the voids between the frame, frame invert and the channel
 - Make a smooth transition for water flow. Therefore, the grout shall be built-up to the level of the frame as shown in Figure 9

CAUTION! Make sure not to get grout or any other foreign material on the gate's seals, guides or stem as this may cause leakage or damage.

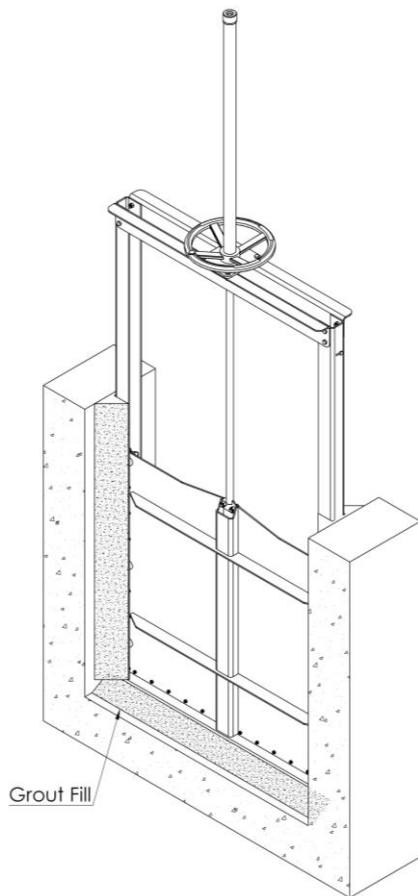

Figure 8

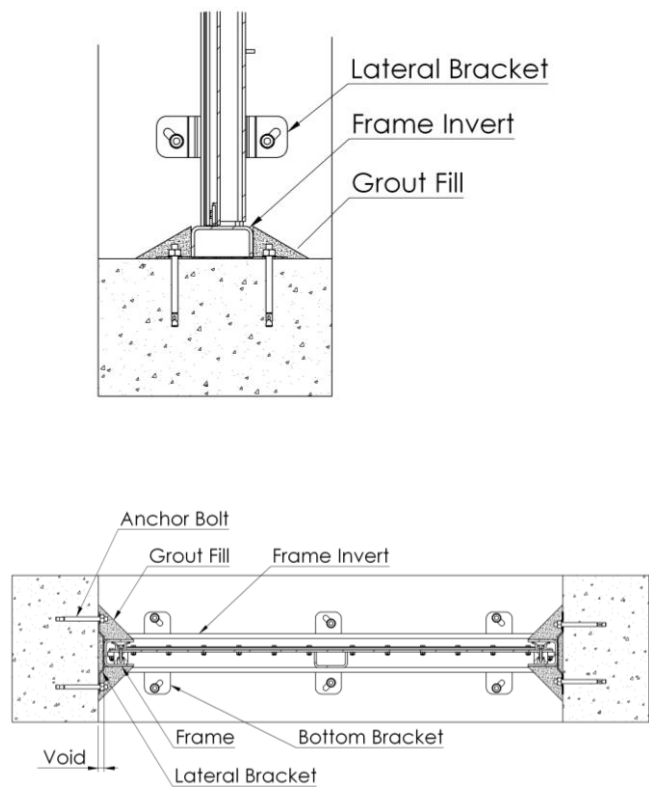

Figure 9

2.3. Installation: Wall Mounted

► Required Materials:

- For the Wall Mount (WM) mounting option, the CC channel gate is installed by means of mechanical anchor bolts and construction sealant (Sikabond/Sikaflex 11FC or equivalent). Note that as standard, anchor bolts and construction sealant are not supplied with the gate. For detailed information about the type, size and quantity of the required anchor bolts, or any other specific installation notes or materials, please refer to the notes on the 'General Arrangement Drawing'.

► Installation Procedure:

Step 1: Concrete construction inspection

- The concrete construction shall be flat, level and plumb, and shall be in accordance to DIN 18202 or ACI 117-06 standards. If necessary, use non-shrink grout in order to meet the specified standard. The minimum concrete strength shall be 25Mpa (3,625 PSI)
- The wall surface shall be dry, for the construction sealant to adhere properly. If necessary, the wall can be dried with the help of a blowtorch or a hot-air fan

Step 2: Pre-installation of the channel gate

- Position the channel gate against the wall and line up with the opening (See Figure 10). The gate shall be in the closed position
- Drill and install an anchor bolt on each side of the gate. After installing the first anchor bolt, and prior to drilling the hole on the other side, make sure the frame is perfectly leveled (see Figure 11)

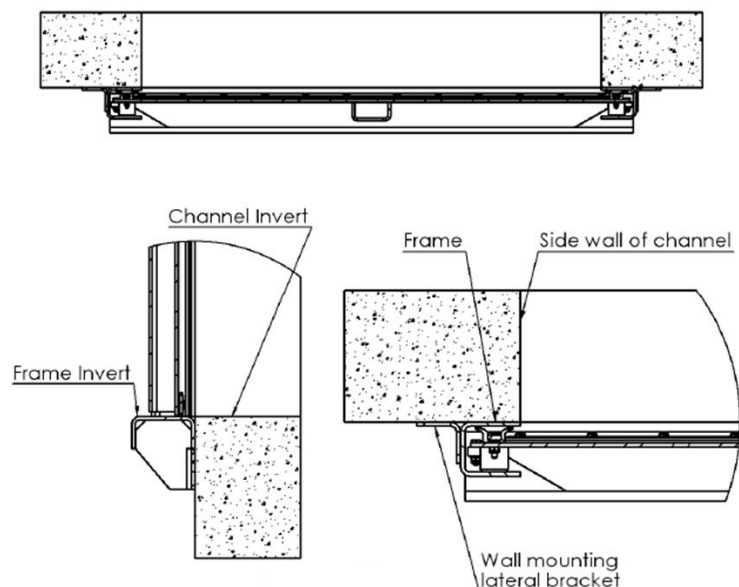

Figure 10

Step 3: Construction sealant application (Sikabond/Sikaflex 11FC or equivalent)

In order to avoid leakage between the frame and the wall, construction sealant shall be applied on the back side of the frame:

- Remove the channel gate from the wall (first remove the nuts of the anchor bolts)
- Apply construction sealant all around the perimeter of the frame, where it will be in contact with the wall. Sikabond/Sikaflex 11FC (200 ml/m) or equivalent construction sealant shall be used (See Figure 12). Be sure not to get sealant on the gate's seals, guides, and/or stem, as this may cause leakage or damage

Step 4: Final installation of channel gate

- Place back the slide gate on the wall
- Drill and install the rest of the anchor bolts (see Figure 13)

CAUTION!: If the channel gate is not completely in contact with the wall, do not over-tighten the anchor bolts. Over tightening may bend or distort the frame. If the wall flatness and levelness is according to the specified standards, the construction sealant will fill in the remaining void (see Figure14)

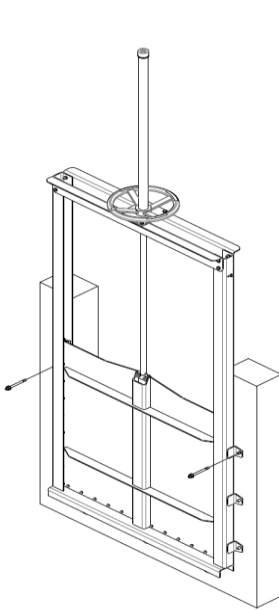

Figure 11

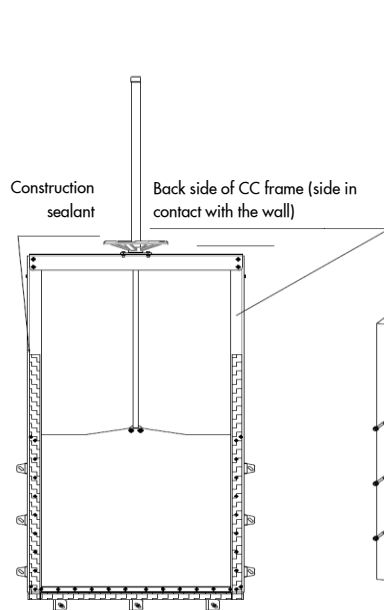

Figure 12

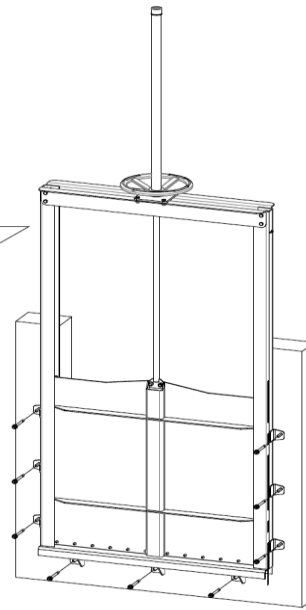

Figure 13

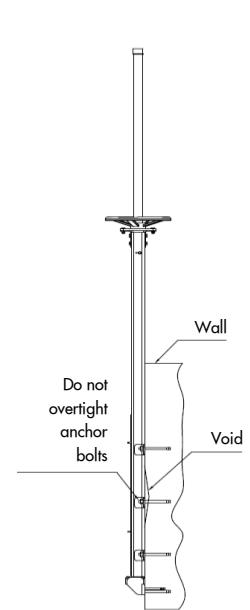

Figure 14

3. OPERATION

Initial Operation:

Before cycling the channel gate, make sure there are no foreign deposits or materials on the seals, guides or sealing area. Gate seals could be damaged if the area is not cleaned and coated with a light grease. Please refer to section *“Materials needed for maintenance and seal replacement”* for detailed information about the required grease type. (see section 4.1)

- **Manual**

Apply a light grease on the stem before initial operation after the installation. If the operation is difficult due to high torque, stop operation of the gate and check stem alignment.

- **Electric actuator**

- Refer to the Electric Motor Instruction Manual section before cycling the slide gate
- Electric actuators must be limited with limit and torque switches. Electric actuators without these limiters shall not be used with ORBINOX channel gates. The electric actuators for CC channel gates are factory set, except in cases where the motor is not yoke-mounted. To adjust the limit switches, follow the next instructions:
 - Position the slide in the nearly closed position (leave 10mm/0,40" open). From this position, manually (using the handwheel) operate the slide until it is completely closed (check tightness with a 0,05mm/0,002" gauge). In this position, set the limit switch for the CLOSED position
 - Position the slide in the nearly open position (leave 10mm/0,40" closed). From this position, manually (using the handwheel) operate the slide until it is completely open. In this position, set the limit switch for the OPEN position
- Be aware when the gate is almost fully OPEN or CLOSED. If the gate does not stop once the fully open or fully closed position is reached, stop immediately and correct adjusting again the limit and torque switches

Operation:

- CAUTION! Do not force the operator to close the gate, as it may cause damage to the stem and it does not improve the sealing system. **The maximum applicable force on the handwheel is 25 kg /55 bs**
- The CC Channel Gate is closed by a clockwise rotation, and opened by a counter-clockwise rotation of the operator
- The CC Channel Gate is designed to be self-locking, so that the slide maintains its position in any position

4. MAINTENANCE

4.1. Cleaning And Lubrication

ORBINOX model CC Channel Gates need practically no maintenance. In order to assure maximum performance of the channel gate, the following maintenance inspections shall be carried out periodically every 6 months:

- Stem and stem nut shall be cleaned and greased. For non-rising stem configurations, the stem may be in contact with water and dirt. Under these conditions, the threads of the stem and/or stem nut may wear, and they shall be checked every 3 months
- Clean the gate with clear water and remove any deposits, especially on the seals and in the guides.
- Check the seals and make sure they are not damaged. Seals shall be replaced if damaged. See section 'Maintenance: Seal Replacement' for detailed procedures about seal replacement. (See section 4.2)
- Seals shall be wet while operating. If the slide gate has not been used for a long period of time under dry conditions, the seals shall be wetted with clear water before operating the channel gate. Operating the gate with dry seals may damage the seals. Additionally, more torque may be required to operate the channel gate

Spare parts:

ORBINOX does not recommend stocking any spare parts by the owner of the equipment as the channel gates are designed for a very long life cycle. If a repair part is required, please contact an ORBINOX representative and provide the following information:

- ORBINOX S/O number
- "ORBINOX General Arrangement Drawing" number
- Project name (if applicable)
- Vendor's company name

Materials needed for maintenance and seal replacement:

Material	Type	Recommended or equivalent
Grease	Silica-Gel Silicone Grease	Verkosil G-2 (no tóxico)
Glue	Instant adhesive	Loctite 406 and Cleaner 770

4.2. Seals Replacement

Slide Removal (Figure 15)

- Step 1: Start from the closed position
- Step 2: Remove bolts and nuts (items 3 and 4) that are used to join the stem (item 5) and slide (item 2). For the non-rising stem configuration, the stem nut shall be detached from the gate
- Step 3: Remove bolts and nuts (item 9 and 10) with caution, as major components of the gate (yoke, operator and stem) are no longer secured. Remove the stem (item 5), yoke (item 8) and the operator (item 11) as one item
- Step 4: Remove bolts and nuts (items 6 and 7) in order to be able to remove the slide.
- Step 5: Remove the slide (item 2)

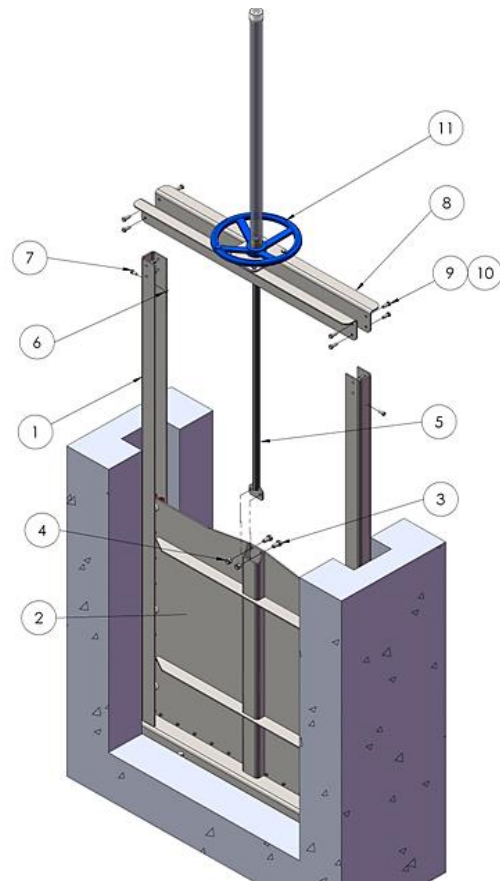

Figure 15

Side seals replacement (Figure 16)

- Step 6: Remove bolts, washers and nuts (items 3, 4 and 7) from the gate and remove retainers (items 2), lateral (U)HMWPE guides (items 4) and front (U)HMWPE guides (items 5)
- Step 7: Remove side seals (item 8) and replace it by the new seal. Apply glue where the bottom seal and side seals join. After installing the new seal, apply grease on it to ease operation

Bottom seal replacement (Figure 16)

- Step 8: Remove bolts and nuts (items 10 and 12) and remove bottom retainer (item 9)
- Step 9: Remove bottom seal (item 13) and replace it by the new seal. Apply glue where the bottom seal and side seals join

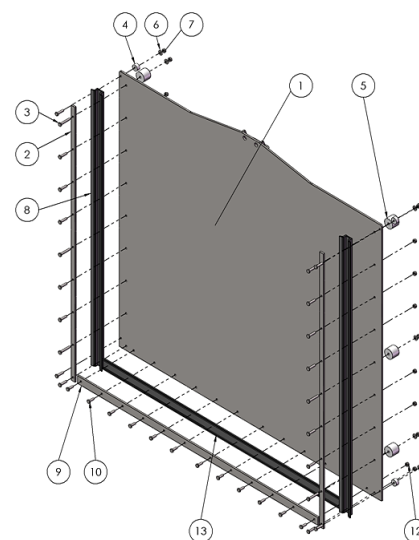

Figure 16

Reassembly

- Follow Steps 9 to 1

5. TROUBLE SHOOTING

SYMPTOM	CAUSE	SOLUTION
Leakage between channel gate and concrete wall (for Face Mounted in Existing Channel Configuration)	Gaps between frame and face of wall due to missapplication of grout fill	Rellenar con mortero expansivo las oquedades
	Loose anchor bolts	Tighten anchor bolts
	Incorrect anchor bolts	Check the 'General Arrangement Drawing' and make sure the right anchor bolts have been installed
Leakage between channel gate and concrete wall (for Wall Mounted Configuration)	Concrete wall does not meet the required std	Un-install the slide gate and fix the wall
	Not enough construction sealant	Un-install the slide gate, clean the wall and apply a new layer of construction sealant
	Loose anchor bolts	Tighten anchor bolts
	Incorrect anchor bolts	Check the 'General Arrangement Drawing' and make sure the right anchor bolts have been installed
Leakage through the side seals	Damaged seal	Replace seal
Leakage through the bottom seal	Foreign material trapped between frame invert and slide	Remove the foreign material. Check if there is any damage to the seal
	Damaged seal	Replace seal
Excessive force required to operate the slide gate	Dirty stem and/or stem nut	Clean and lubricate stem and/or stem nut

6. ANNEX: CIVIL WORK TOLERANCES

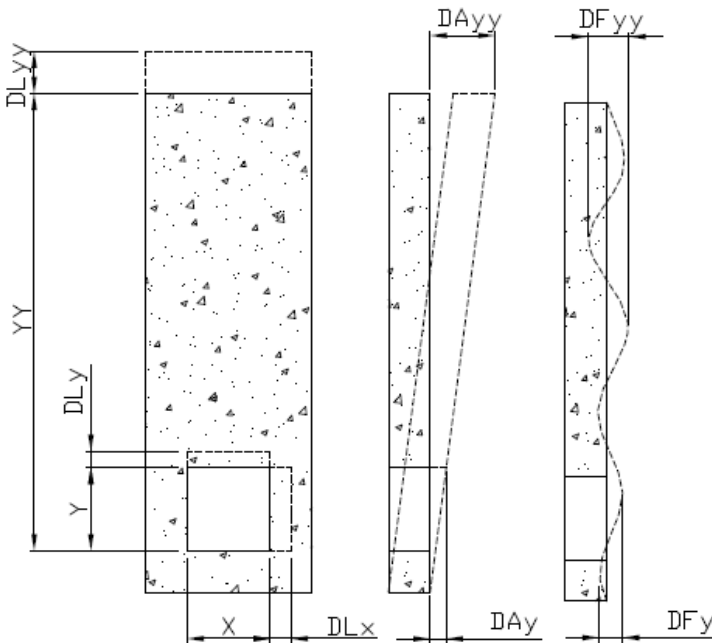

- X: opening width
- Y: opening height
- YY: invert to coping distance
- DLx: linear deviation (with respect to X dimension)
- DLy: linear deviation (with respect to Y dimension)
- DLYy: linear deviation (with respect to YY dimension)
- DAy: angular deviation (with respect to Y dimension)
- DAX: angular deviation (with respect to X dimension)
- DAyy: angular deviation (with respect to YY dimension)
- DFy: flatness deviation (with respect to Y dimension)
- DFx: flatness deviation (with respect to X dimension)
- DFyy: flatness deviation (with respect to YY dimension)

Deviations shall be within the tolerances defined in DIN 18202:

Deviation	Maximum deviation
Linear deviation (DLx, DLy, DLYy)	DIN 18202, table 1, group 2 (for DLx and DLy) DIN 18202, table 1, group 5 (for DLYy)
Angular deviation (DAX, DAy, DAyy)	DIN 18202, tabla 2
Flatness deviation (DFx, DFy, DFyy)	DIN 18202, tabla 3, grupo 7

The following tables show the tolerances defined in DIN18202:

DIN 18202 TABLE 1	Group	Applicable to	Max. admissible deviation (mm) for target size (m)					
			≤ 1	> 1 ≤ 3	> 3 ≤ 6	> 6 ≤ 15	> 15 ≤ 30	> 30
Linear deviation	Group 2	DLx, DLy	+10	+12	+16	-	-	-
	Group 5	DLYy	+10	+16	+16	+20	+30	+30

DIN 18202 TABLE 2	Group	Applicable to	Max. admissible deviation (mm) for target size (m)						
			≤ 0,5	> 0,5 ≤ 1	≥ 1 < 3	≥ 3 < 6	≥ 6 < 15	≥ 15 ≤ 30	≥ 30
Angular deviation		DAX, DAy, DAyy	3	6	8	12	16	20	30

DIN 18202 TABLE 3	Group	Applicable to	Max. admissible deviation (mm) for target size (m)				
			< 0,1	≥ 0,1 < 1	≥ 1 < 4	≥ 4 < 10	≥ 4 < 10
Flatness deviation	Group 7	DFx, DFy, DFyy	2	3	8	15	20

7. ENVIRONMENTAL CONSIDERATIONS

- The packaging is made from environmentally friendly materials. Dispose of the packaging through the available recycling channels
- The valve is designed and manufactured with materials that can be recycled by specialised recycling firms. Once the life of the product is expired, you have to consider a proper disposal of the product in order to prevent any negative impact on the environment and allows for the recycling of valuable commodities
- Please follow the local environmental rules in your country for proper disposal